

Fitting instructions

Make: Citroën

C5

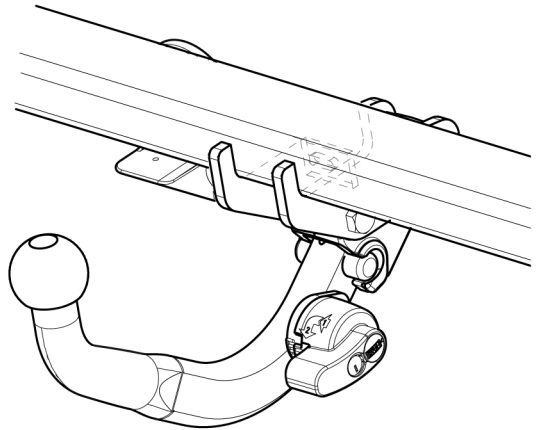







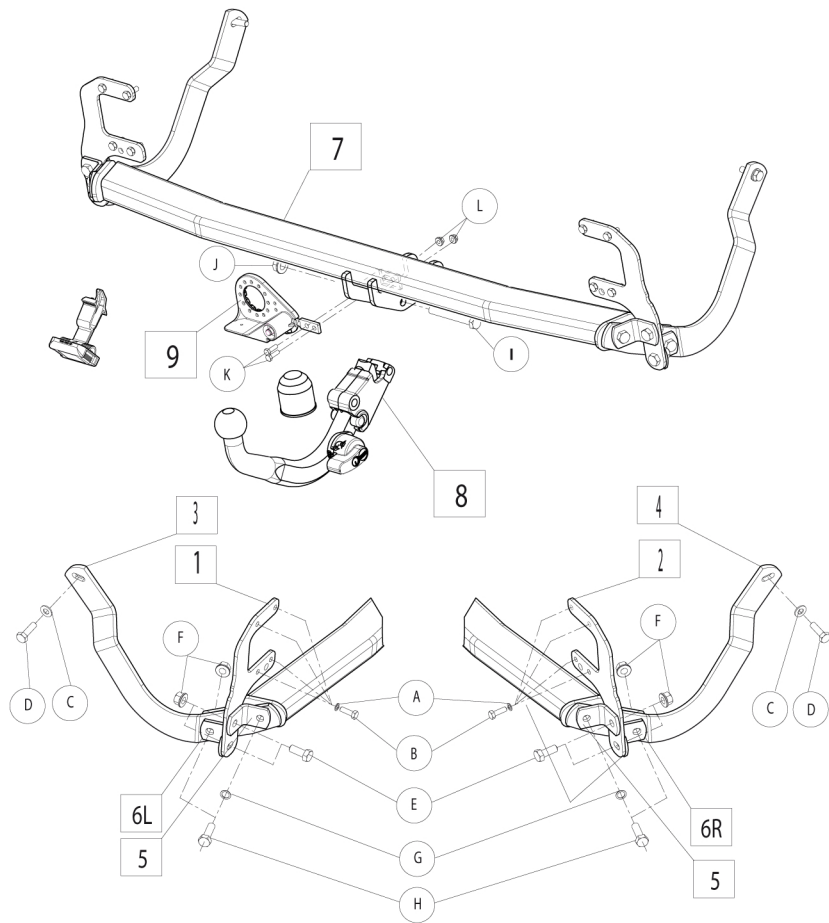

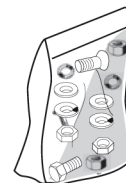
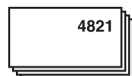
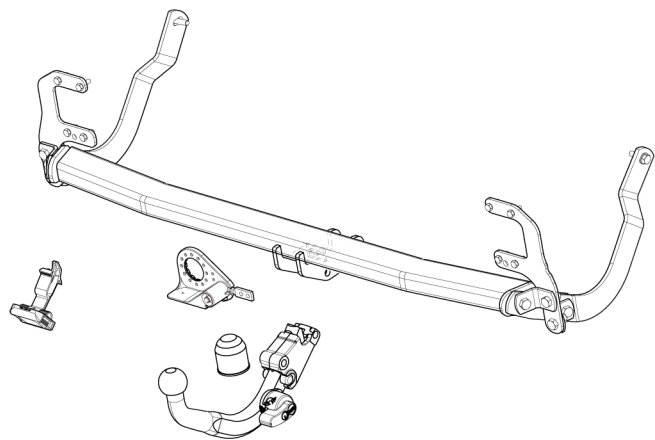
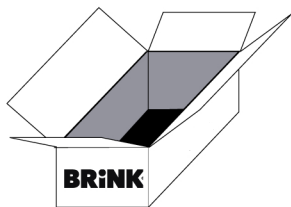



- NL Montagehandleiding
- GB Fitting instructions
- D Montageanleitung
- F Instructions de montage
- S Monteringsanvisningar
- DK Montagevejledning
- E Instrucciones de montaje
- I Istruzioni per il montaggio
- PL Instrukcja montażu
- SF Asennusohjeet
- CZ Pokyny k montáži
- H Szerelési útmutató
- RUS Руководство для монтажа

BRiNK[®]

Your perfect fit
brink.eu

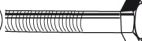



- | | | |
|----------|--|--------------------------|
| A |  | x8 HM8 |
| B |  | x8 M8 Schnor |
| C |  | x2 M10 |
| D |  | x2 HM10X35 |
| E |  | x4 Hm12x30 |
| F |  | x6 HM12 |
| G |  | x2 M12 Schnor |
| H |  | x4 HM12x40 |
| I |  | x2 HM12x90 (10.9) |
| J |  | x2 HM12 (10) |
| K |  | x2 HM6x20 (8.8) |
| L |  | x2 HM6 (8) |

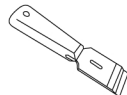
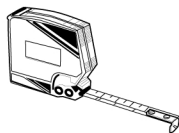
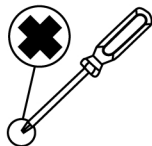
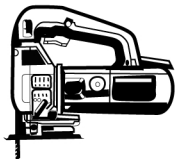
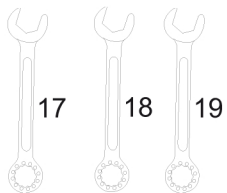
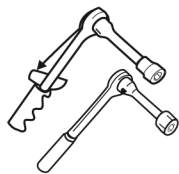

Couplingsclass: A50-X



94/20/EC



e11 00-7073

D-Value : 10,31 kN

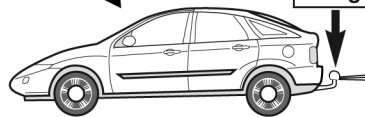

kg ?

kg

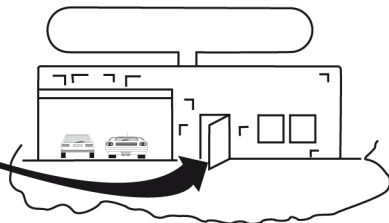

8.8
8



MODIFICATION?

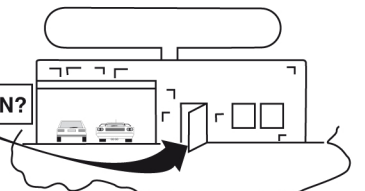



NOTE:

* Should this installation process entail the cutting of the bumper – conformation **MUST** be obtained by the installation engineer of the customer's acceptance prior to completion. Brink Towing Systems do not accept responsibility for any matters arising as a result of this miscommunication.

All measurements are in mm!

HINWEISE:

* Die für das Fahrzeug zugelassene Anhängelast ist den Fahrzeug Unterlagen zu entnehmen. Bei Änderungen des Fahrzeuggewichtes muß die höchstzulässige Anhängelast gegebenenfalls aus dem D-Wert nachgerechnet werden.

Auskunft hierüber kann Ihr Fachhändler oder der TÜV geben.

* Elektrische Anlage gemäß StVZO anbringen.



1

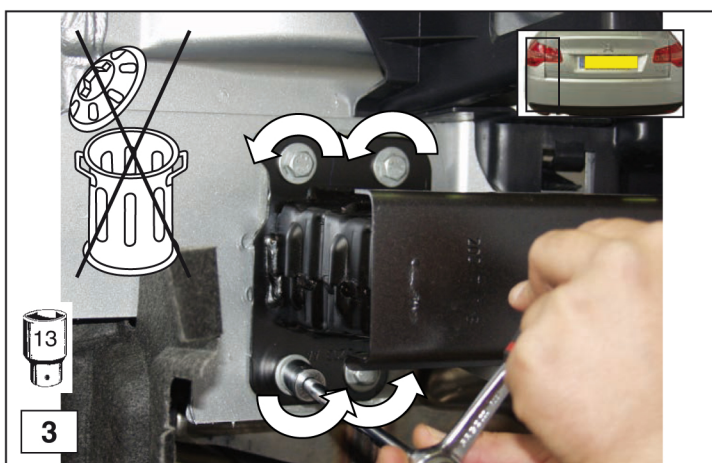

3

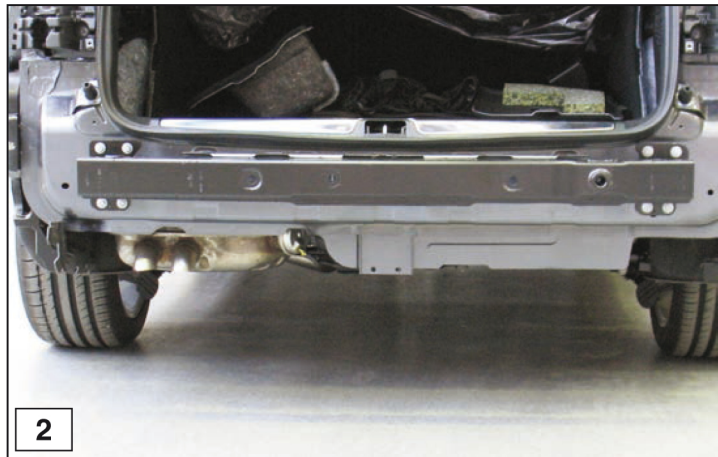

2

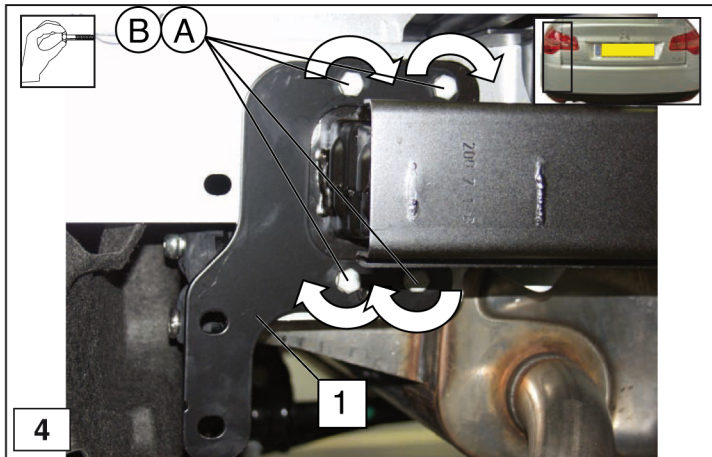

4

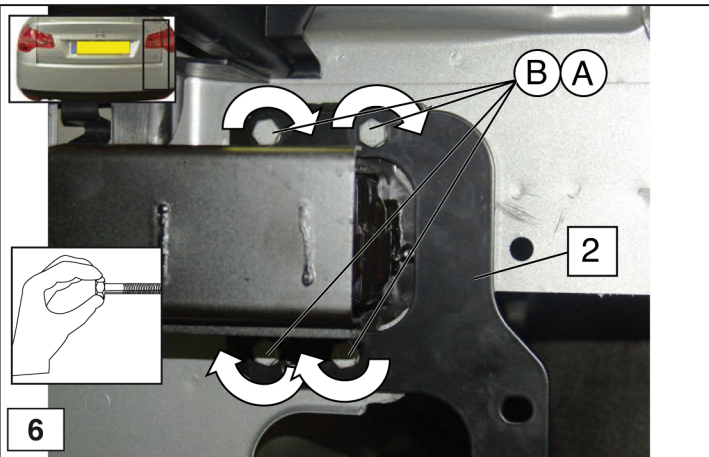
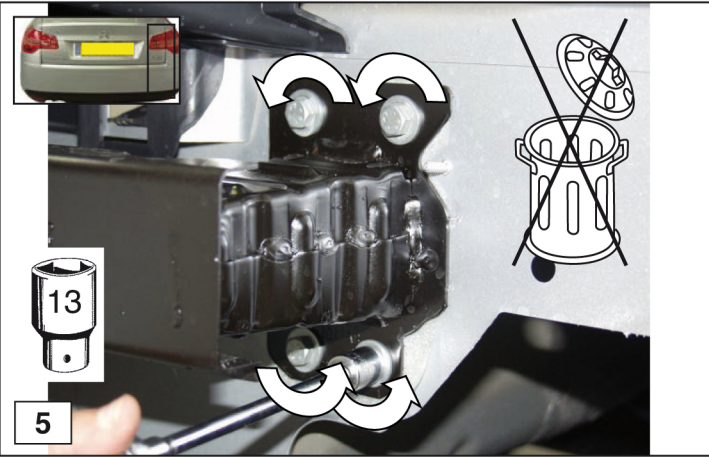

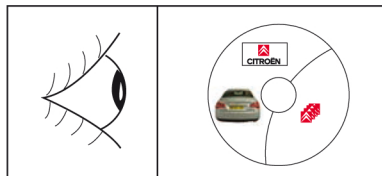
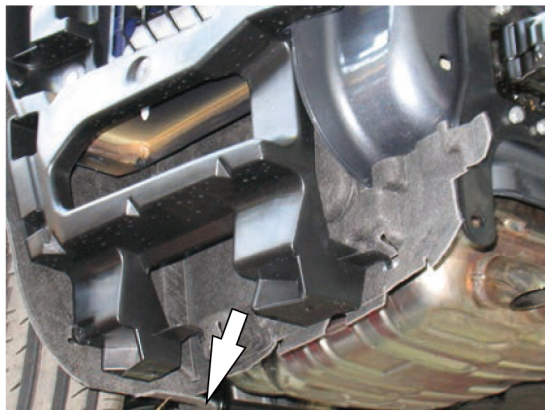

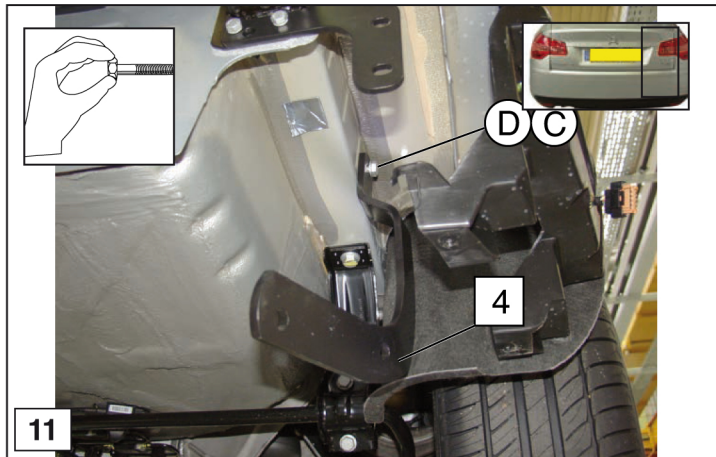
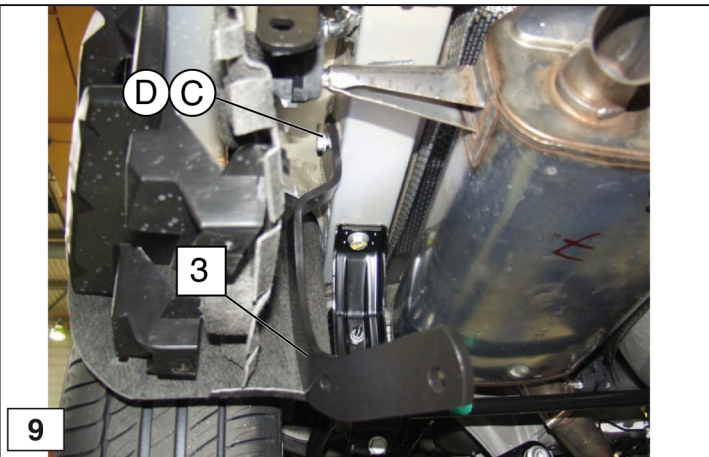
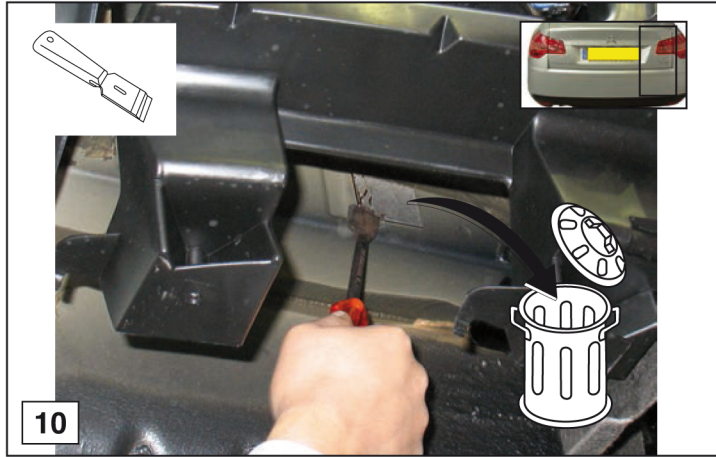
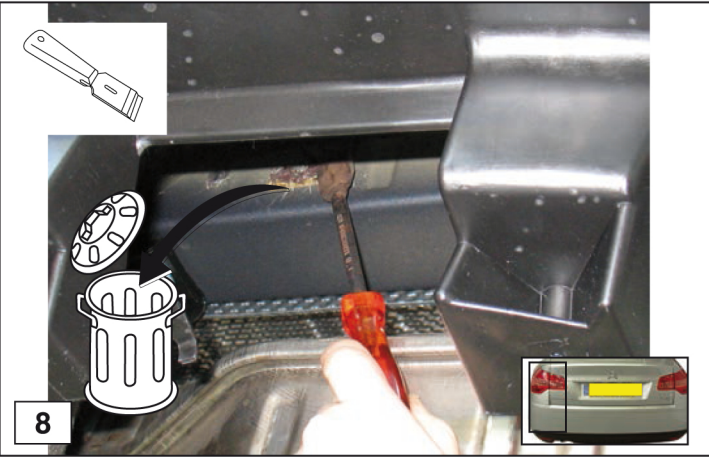

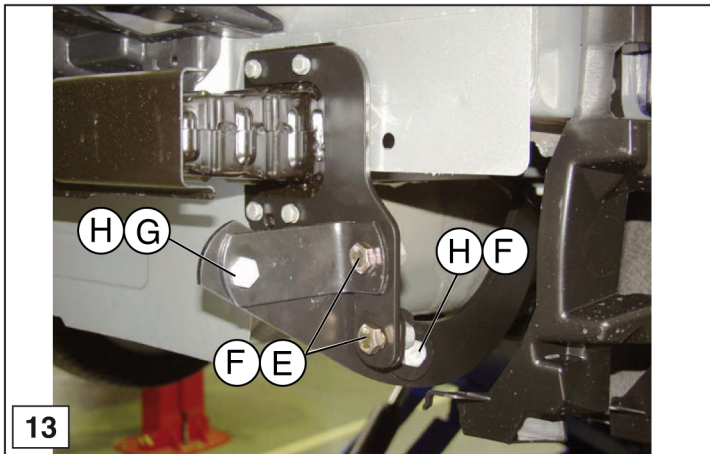
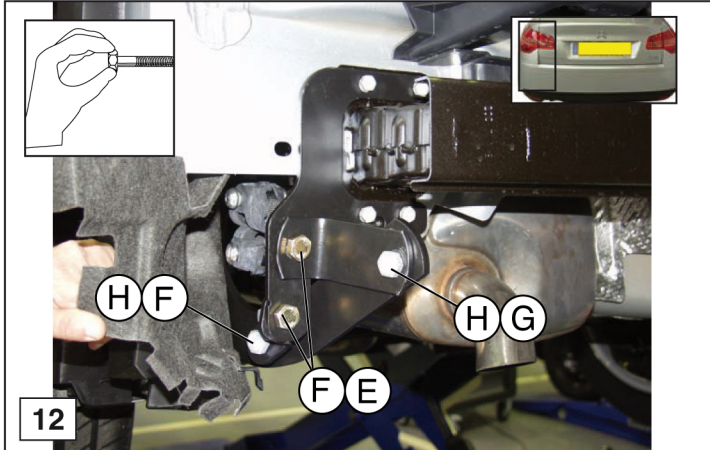

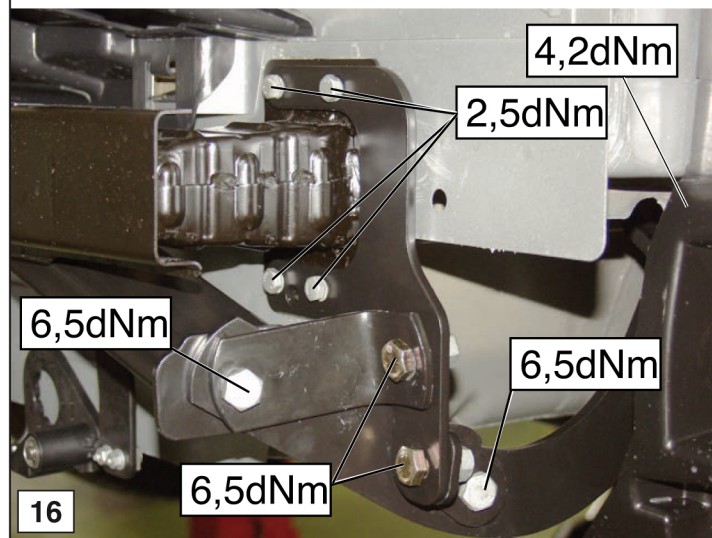
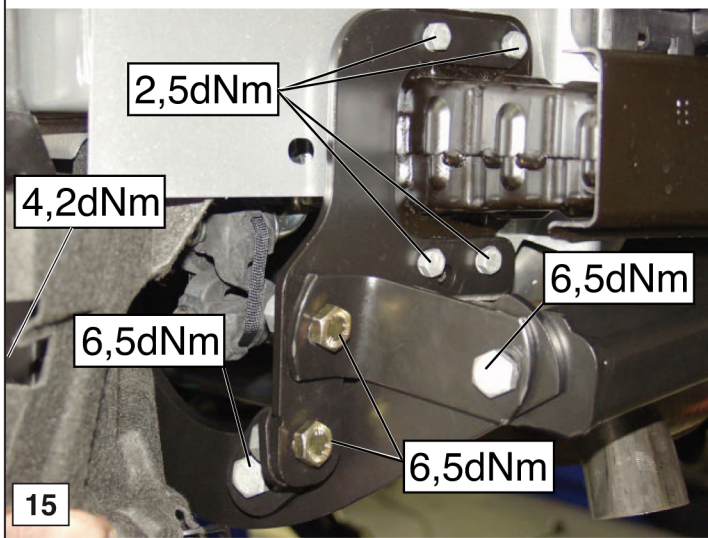
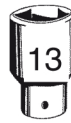

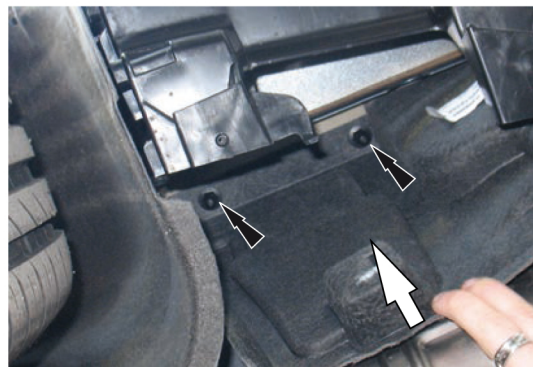
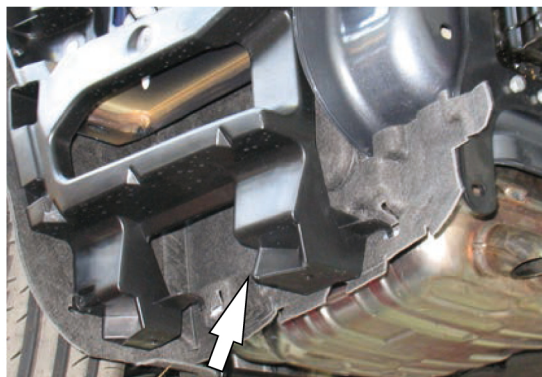
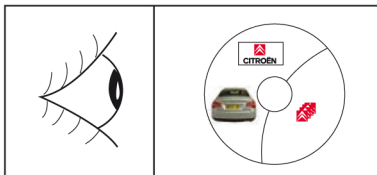

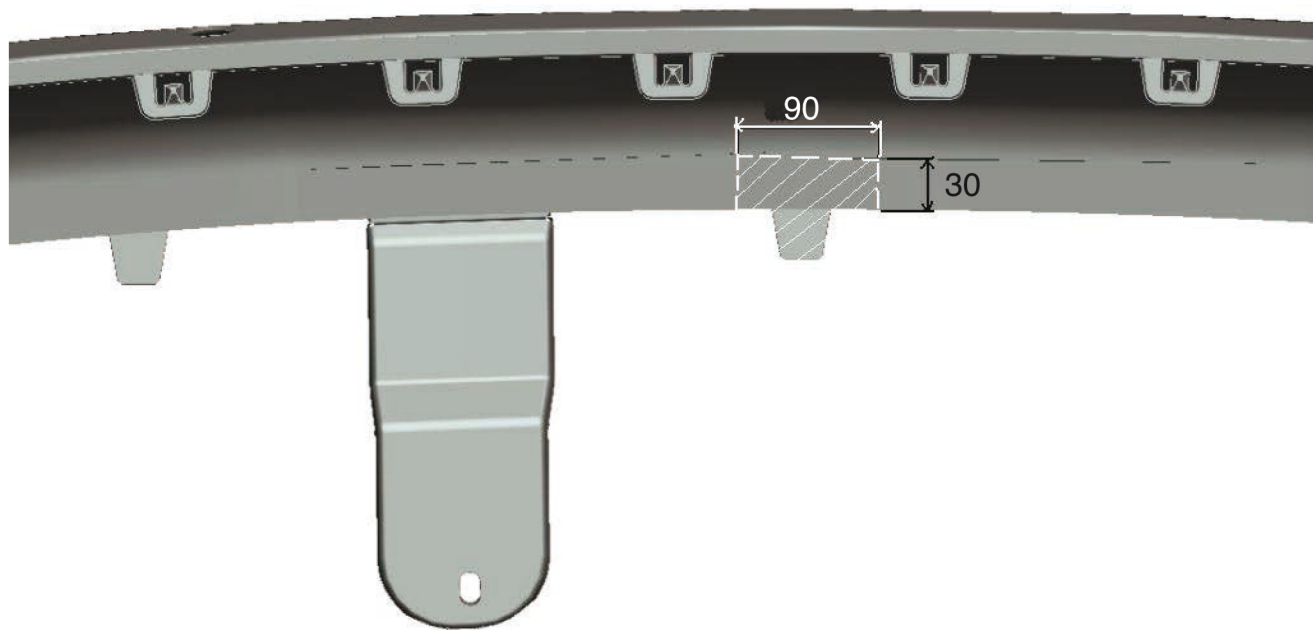
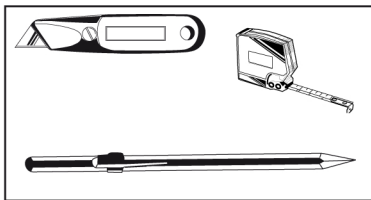





21

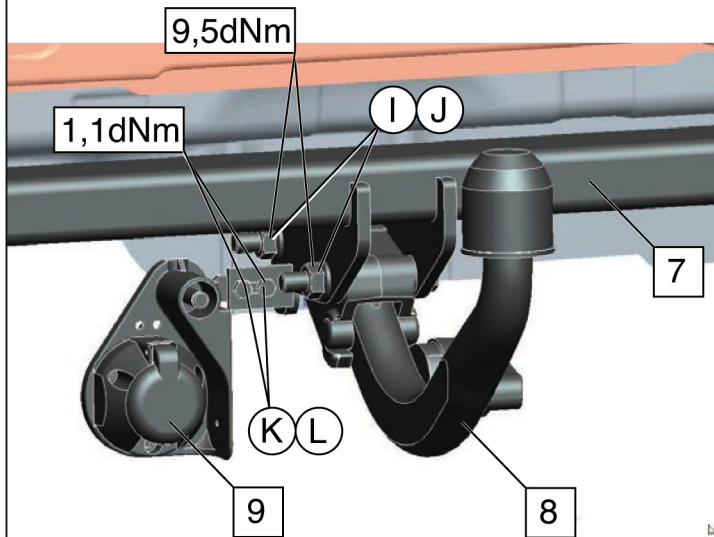
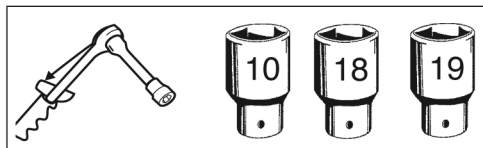

22