

**VW SHARAN
FORD GALAXY
SEAT ALHAMBRA**

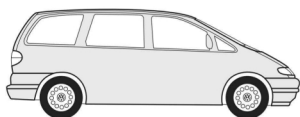

VW SHARAN 09/97- 05/00

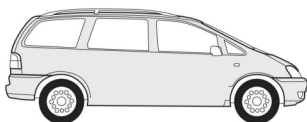

FORD GALAXY 09/97- 05/00

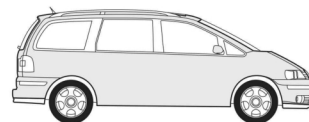

SEAT ALHAMBRA 09/97- 05/00

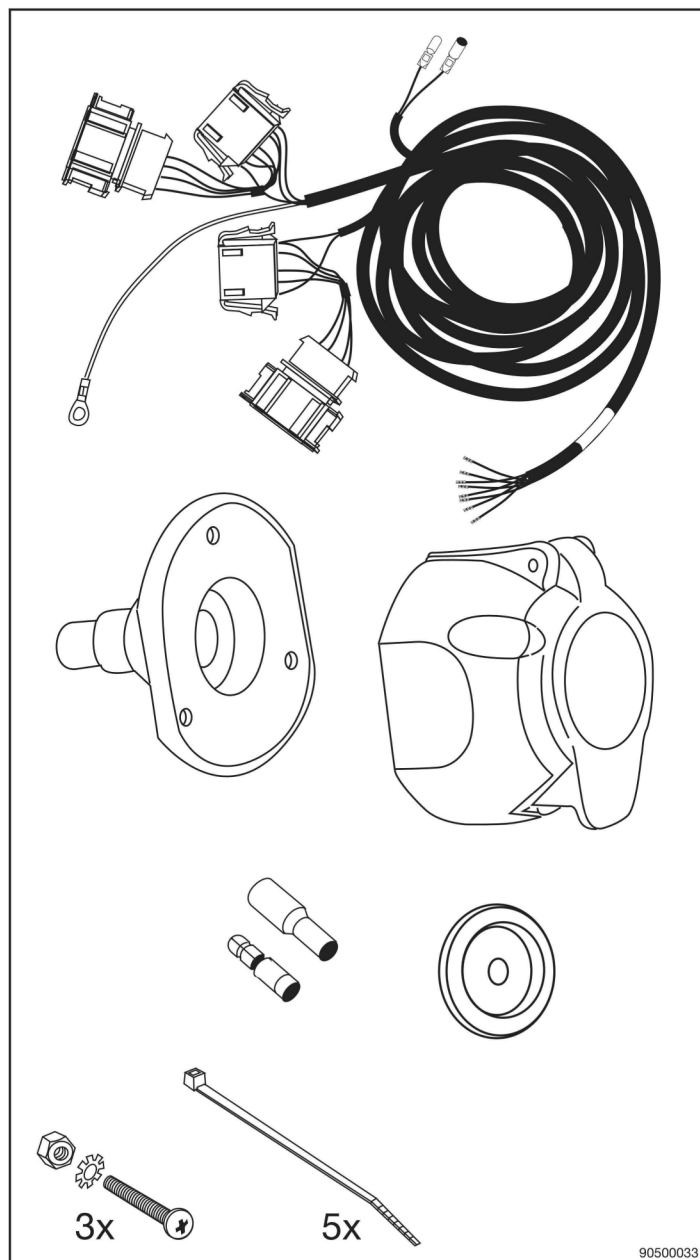
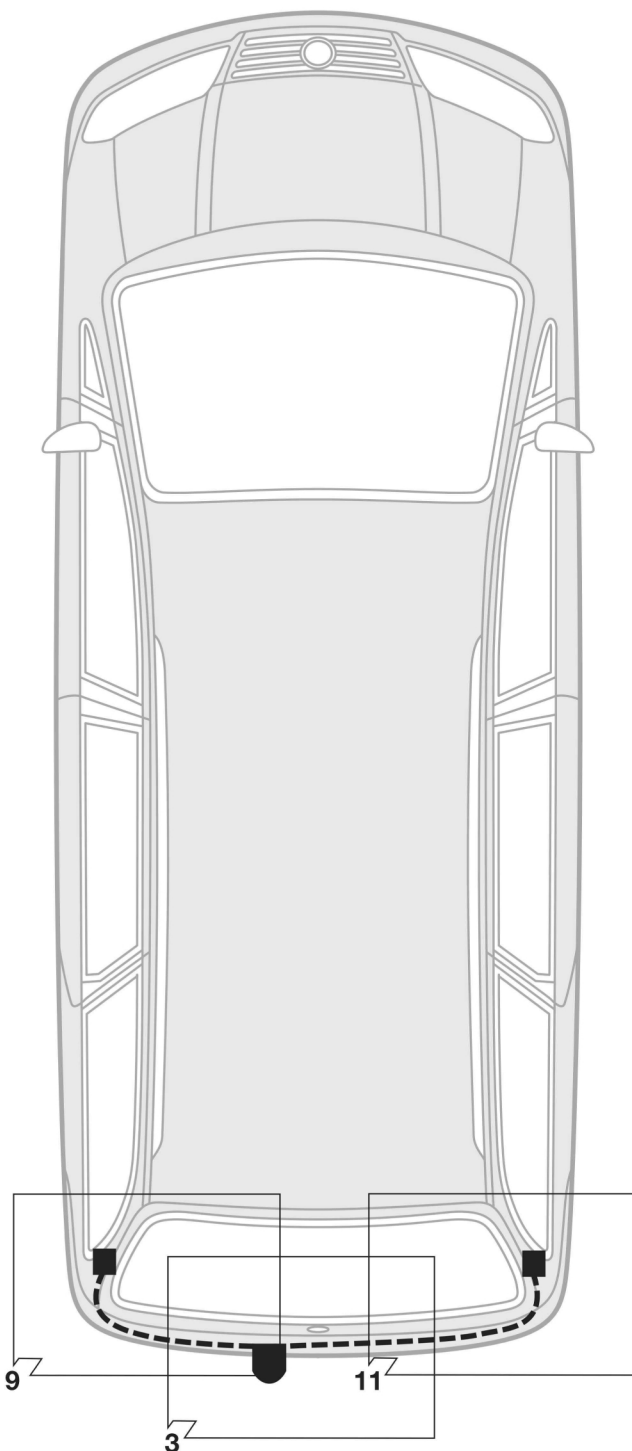

90500033

Änderungen bezüglich Konstruktion, Ausstattung, Farbe sowie Irrtum vorbehalten. Angaben und Abbildungen unverbindlich.

We reserve the right to alter the design, equipment, colour and any errors. All details and illustrations are nonbinding.

Sous réserve de modifications de construction, équipement, couleurs ou erreur. Données et illustrations sous toute réserve.

Con riserva di modifiche relative a costruzione, equipaggiamento, colore, nonché errore. Dati ed illustrazioni non sono vincolanti.

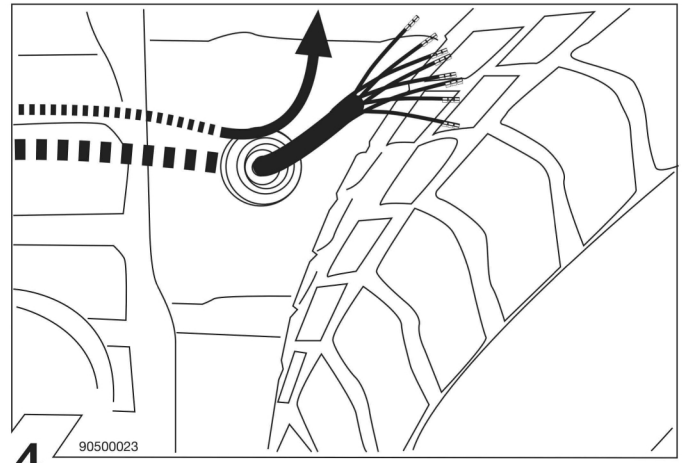
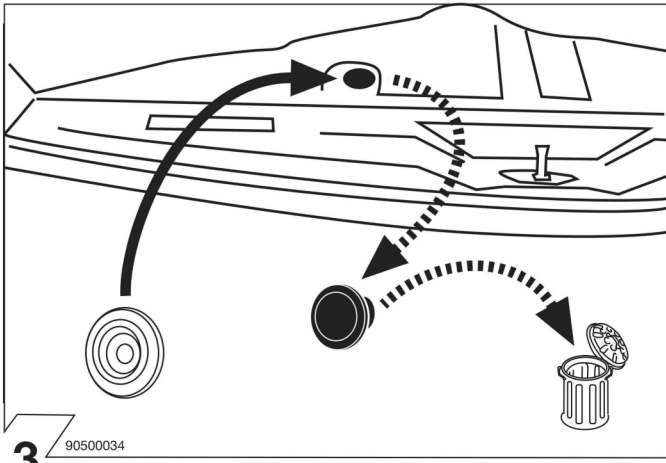
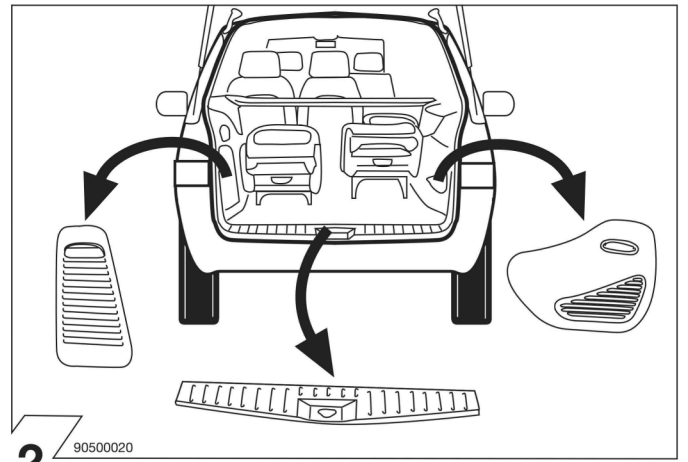
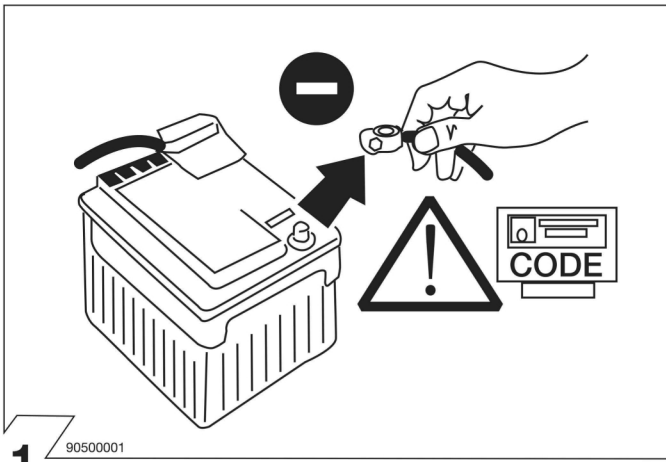

	Anschluss Steckdose	Connection de la prise	Socket connection	Contatto la presa
1/L	schwarz/weiss	noir/blanc	black/white	nero/bianco
2/54g	weiss	blanc	white	bianco
3/31	braun	marron	brown	marrone
4/R	schwarz/grün	noir/vert	black/green	nero/verde
5/58-R	grau/rot	gris/rouge	grey/red	grigio/rosso
6/54	schwarz/rot	noir/rouge	black/red	nero/rosso
7/58-L	grau/schwarz	gris/noir	grey/black	grigio/nero
8/58b	schwarz	noir	black	nero

5 90500003

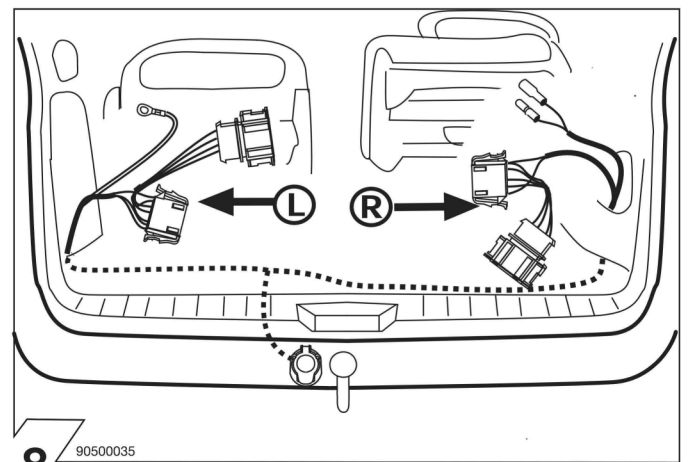
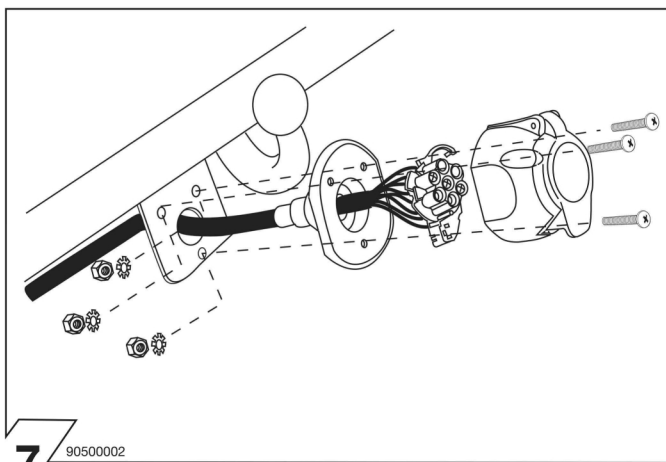
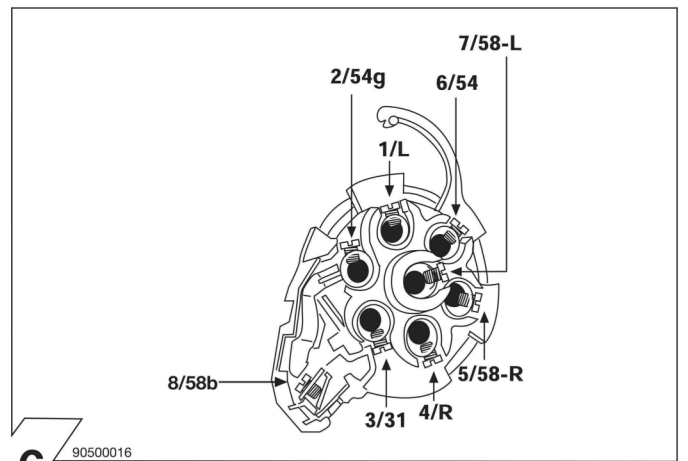

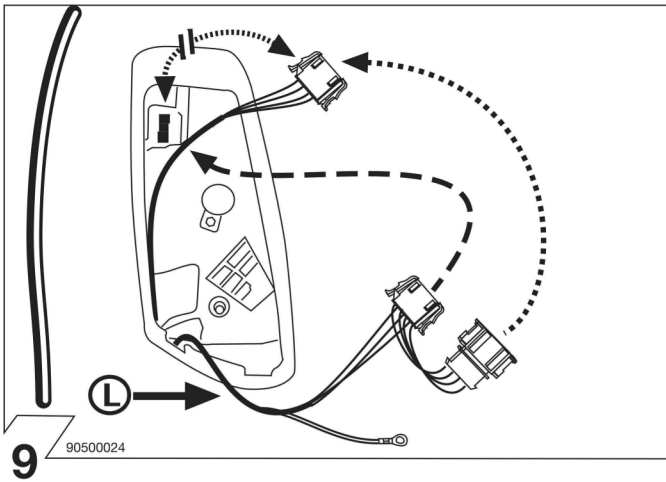

9 90500024

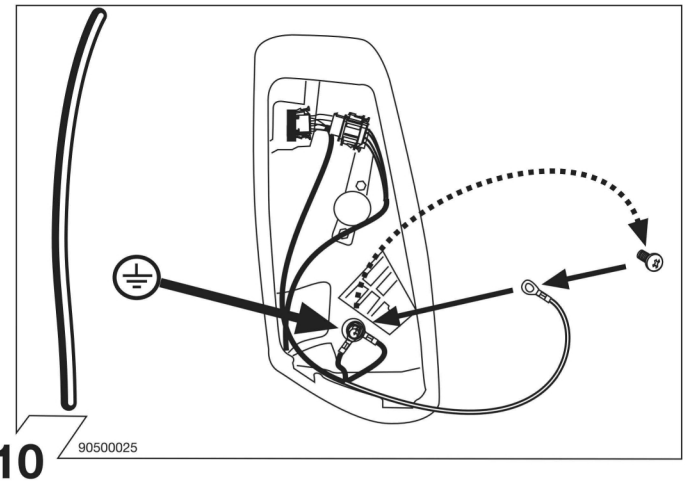

10 90500025

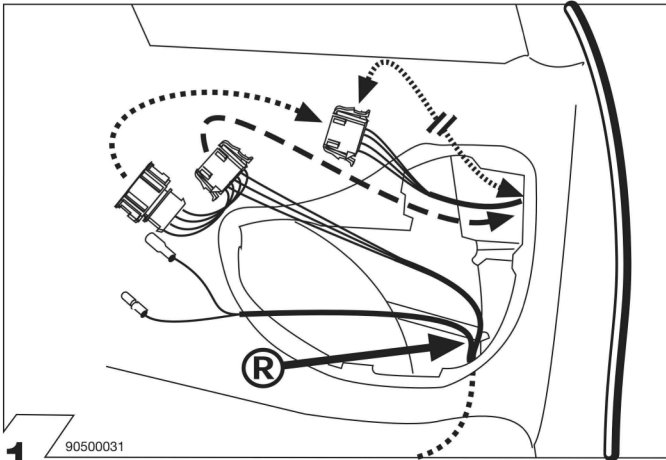

11 90500031

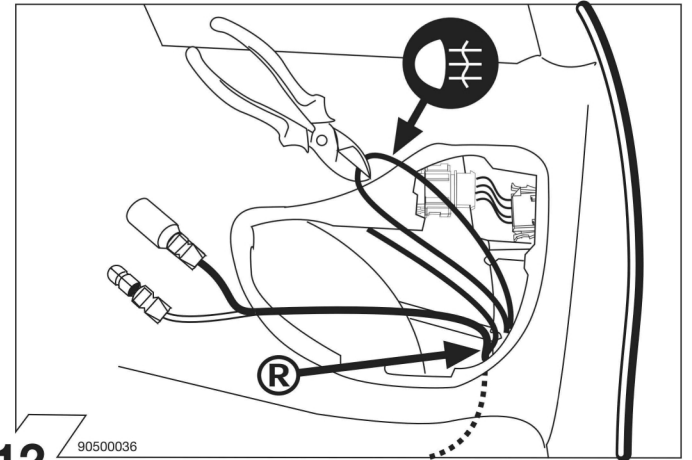

12 90500036

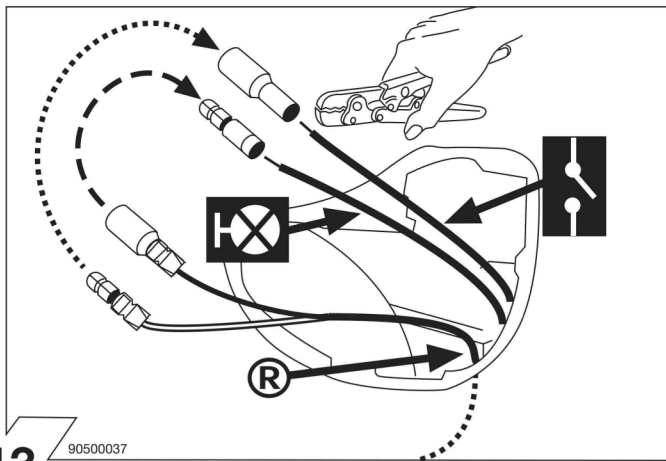

13 90500037

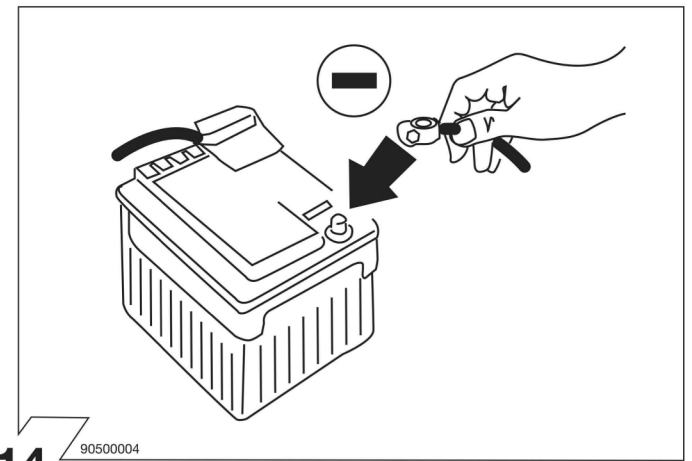

14 90500004

HINWEIS



Die zusätzliche Blink-Kontroll-Leuchte (C2) zur Kontrolle der Fahrtrichtungsanzeiger am Anhänger ist bereits fahrzeugseitig vorhanden und entsprechend vorkonfektioniert !!

Das Steuergerät bzw. die Multifunktionseinheit (ISU) des Fahrzeuges muß mit einem speziellen V.A.G.-Service-Tester (Typ 5051, 1551 oder 1552) nach dem Einbau der Anhängervorrichtung gemäß des Leitfadens Karosserie/Eigendiagnose parametrisiert werden !! (Ford: FDS 2000-Testsystem)

Erst danach wird die zusätzliche Kontroll-Leuchte (C2) im Anhängerbetrieb aktiviert !!

15 90500029

NOTE



The additional turn signal indicator lamp (C2) for monitoring the turn signals on the trailer is already fitted to the vehicle and appropriately prepared !!

The control unit / multi-function unit (ISU) of the vehicle must be parameterised with a special V.A.G.-service-tester (model 5051, 1551 oder 1552) after installation of the towing hitch in accordance with the guideline Body/Self-diagnosis !! (Ford: FDS 2000-Testsystem)

Only thereafter is the additional turn signal indicator lamp (C2) in trailer operation activated !!

16 90500030

REMARQUE



Le voyant clignotant supplémentaire (C2) pour le contrôle des clignotants de la remorque est déjà présent dans le véhicule et confectionné en conséquence !!

L'appareil de commande ou l'unité multifonctions (ISU) du véhicule doit être paramétré avec un testeur V.A.G. spécial (type 5051, 1551 ou 1552) conformément au guide Carrosserie/Autodiagnostic après le montage du dispositif d'attelage !! (Ford: FDS 2000-Testsystem)

Le voyant de contrôle supplémentaire (C2) n'est activé qu'après en mode remorquage !!

17

90500031

AVVISO



La spia supplementare dei lampeggiatori (C2) per il controllo dei lampeggiatori direzionali del rimorchio è già montata sul veicolo e perfezionata in relazione !!

La centralina di controllo o l'unità multifunzionale (ISU) del veicolo deve essere parametrizzata con uno speciale V.A.G. Service Tester (tipo 5051, 1551 oppure 1552) dopo che è stato montato il dispositivo per il rimorchio come descritto nella guida Carrozzeria/Autodiagnosi !! (Ford: FDS 2000-Testsystem)

Solo dopo tale momento viene attivata la spia supplementare (C2) durante la marcia con rimorchio !!

18

90500032



Funktionskontrolle!
Check functions!
Contrôler les Fonctions!
Provo di funzionamento!

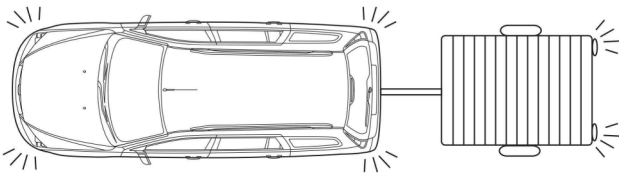

19

90500005

Die Einbauanleitung ist dem Kunden als Betriebsinformation zu übergeben.

Fitting instruction is to be handed to the customer!

La notice de montage doit être remise au client!

Le istruzioni di montaggio devono essere consegnate al cliente!



20

90500006