

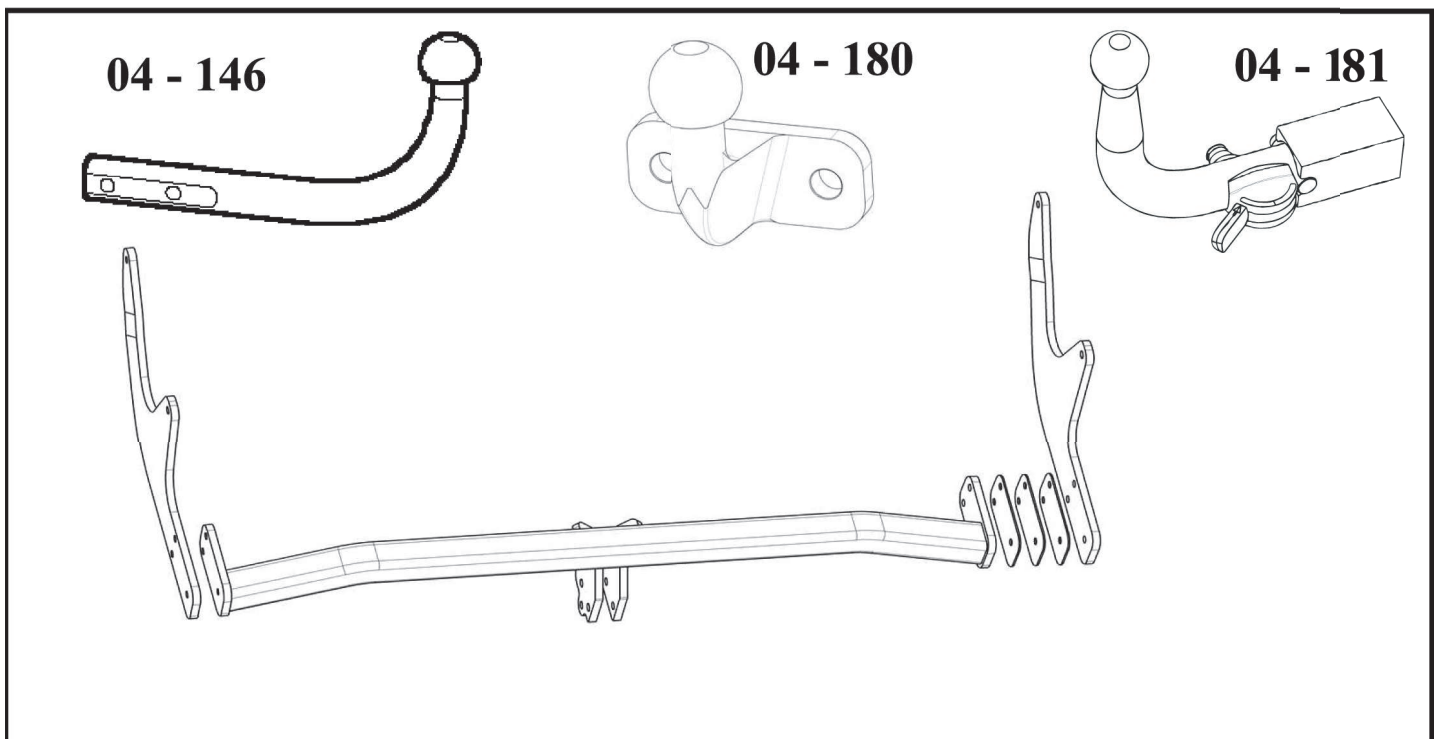









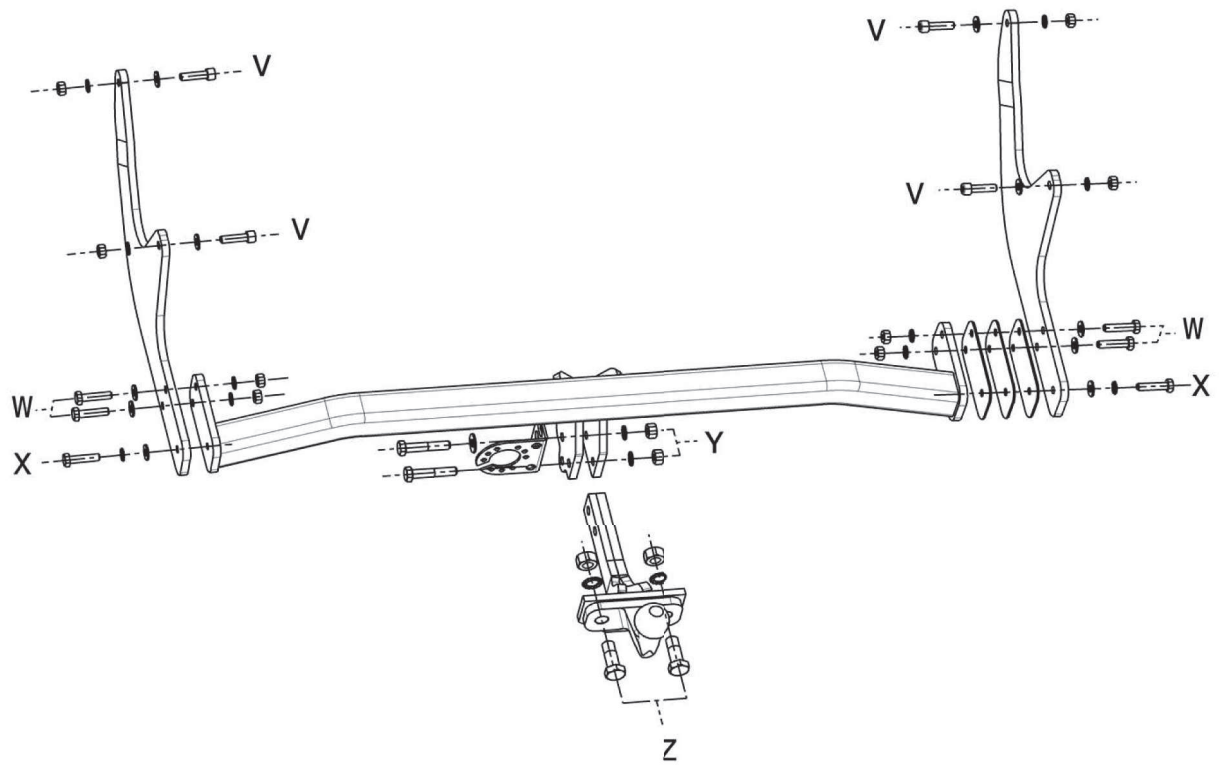









SIARR

WESTFALIA

	75 kg	2 000kg
<p><b>DACIA Logan Van / SUV / Break / Pick up</b></p>	1 300 kg	
	04-146 : 22,6 kg 04-180 : 24,2 kg 04-181 : 20 kg	
	<p>60 min</p>	7,73 kN e24*94/20*01*0153 - 04146 / 04180 e24*94/20*01*0154 - 04181







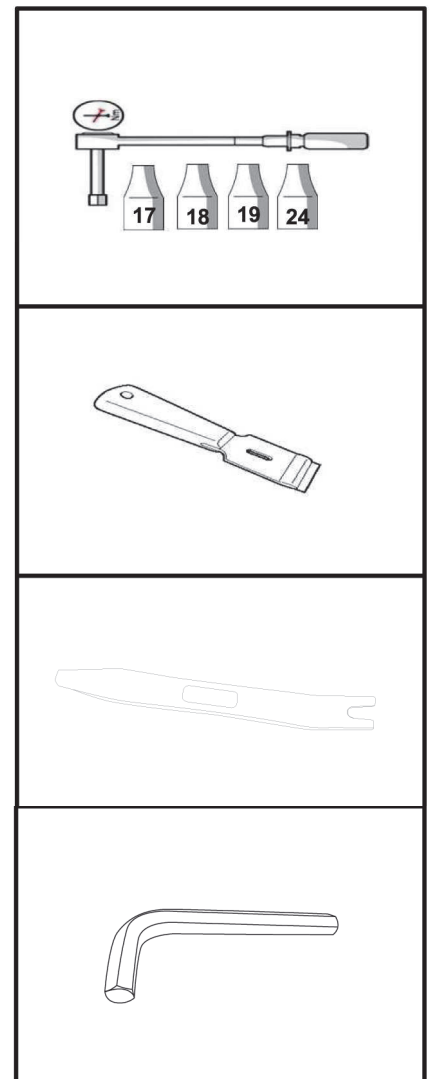

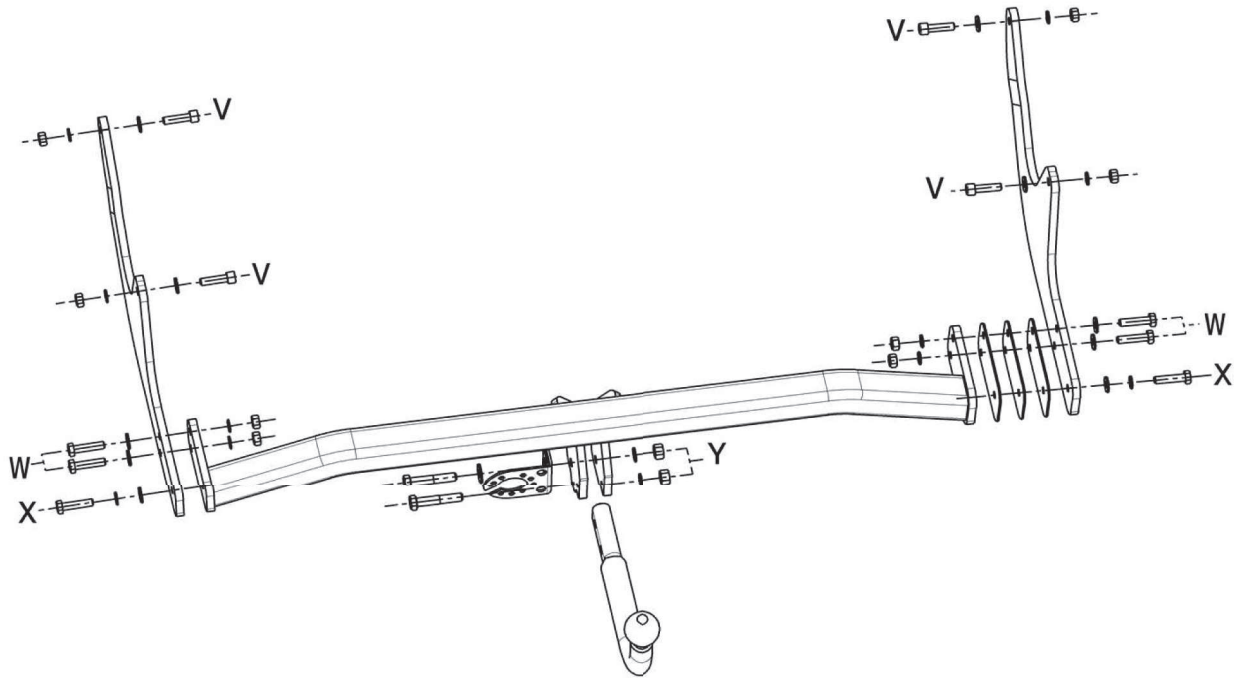









<b>V</b>		CHC10x35 - cl 8.8 - 40Nm	x 4
		DEC10	x 4
		L 10,5/22	x 4
		M10 - cl 8 - 40Nm	x 4
<b>W</b>		HM10x40 - cl 8.8 - 40 Nm	x 4
		DEC10	x 4
		L 10,5/22	x 4
		M10 - cl 8 - 40 Nm	x 4
<b>X</b>		HM10x40 - cl 8.8 - 40 Nm	x 2
		L 10,5/22	x 2
		DEC10	x 2
<b>Y</b>		HM12x60 - cl 8.8 - 65 Nm	x 2
		DEC12	x 2
		M12 - cl 8.8 - 65 Nm	x 2
		L 12/27	x 1
<b>Z</b>		HM16x45 - cl 8.8 - 170 Nm	x 2
		DEC16	x 2
		M16 - cl 8.8 - 170 Nm	x 2







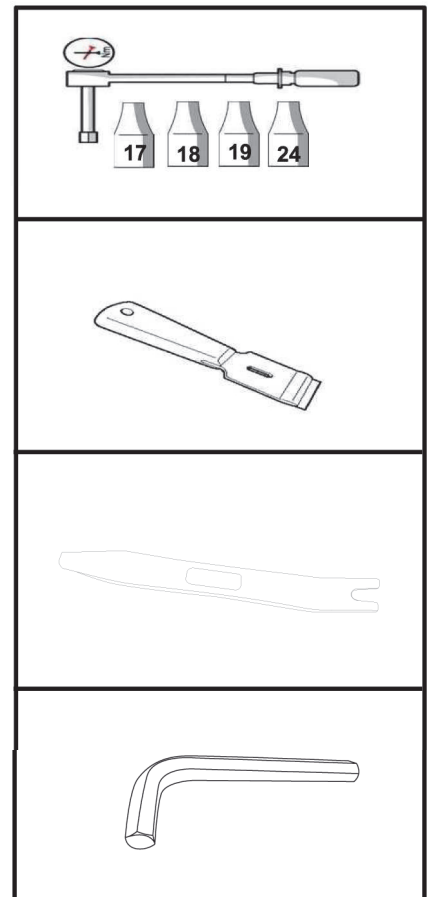

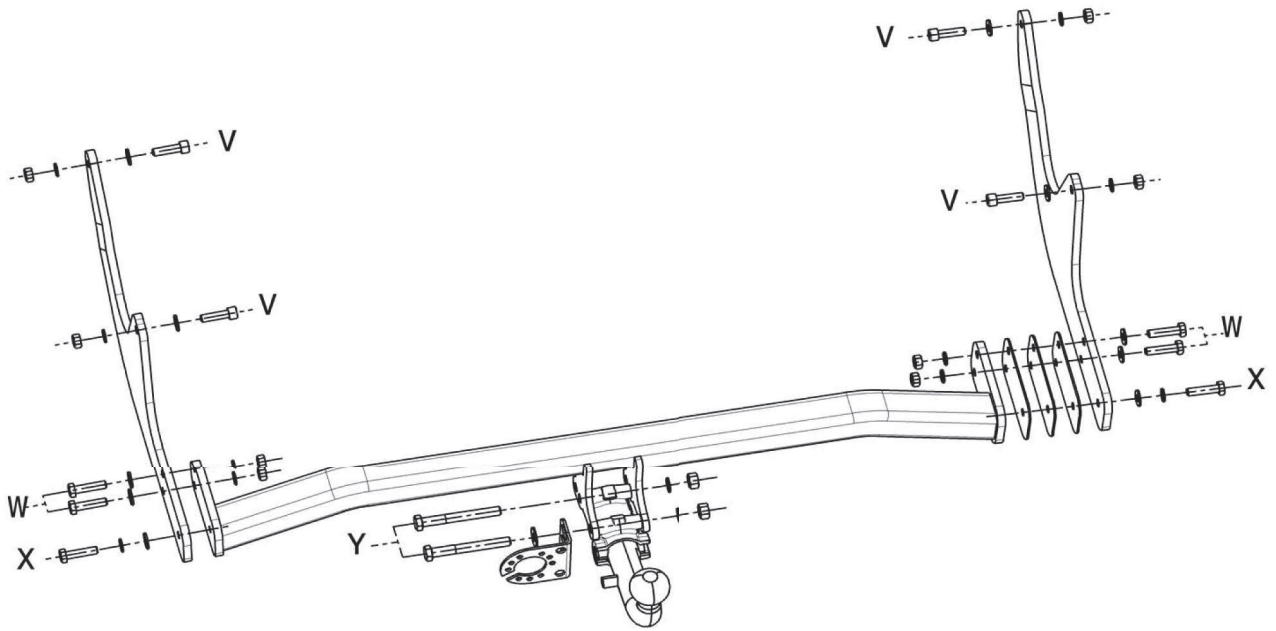









<b>V</b>		CHC10x35 - cl 8.8 - 40Nm	x 4
		DEC10	x 4
		L 10,5/22	x 4
		M10 - cl 8 - 40Nm	x 4
<b>W</b>		HM10x40 - cl 8.8 - 40 Nm	x 4
		DEC10	x 4
		L 10,5/22	x 4
		M10 - cl 8 - 40 Nm	x 4
<b>X</b>		HM10x40 - cl 8.8 - 40 Nm	x 2
		L 10,5/22	x 2
		DEC10	x 2
<b>Y</b>		HM12x60 - cl 8.8 - 65 Nm	x 2
		DEC12	x 2
		M12 - cl 8.8 - 65 Nm	x 2
		L 12/27	x 1





<b>V</b>		CHC10x35 - cl 8.8 - 40Nm	x 4
		DEC10	x 4
		L 10,5/22	x 4
		M10 - cl 8 - 40Nm	x 4
<b>W</b>		HM10x40 - cl 8.8 - 40 Nm	x 4
		DEC10	x 4
		L 10,5/22	x 4
		M10 - cl 8 - 40 Nm	x 4
<b>X</b>		HM10x40 - cl 8.8 - 40 Nm	x 2
		L 10,5/22	x 2
		DEC10	x 2
<b>Y</b>		HM12x100 - cl 10.9 - 95 Nm	x 2
		DEC12	x 2
		M12 - cl 10 - 95 Nm	x 2
		L 12/27	x 1

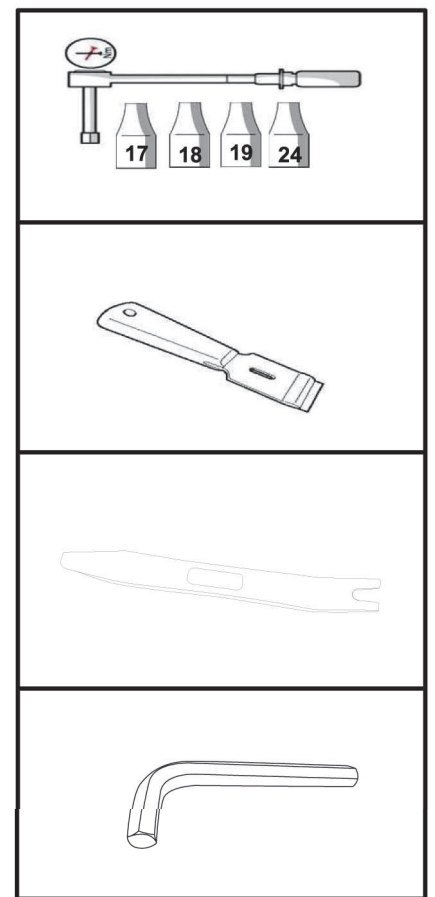

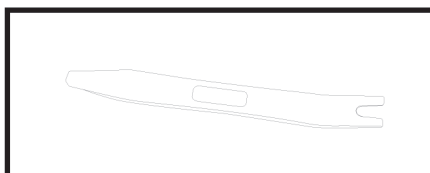
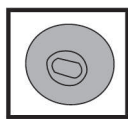
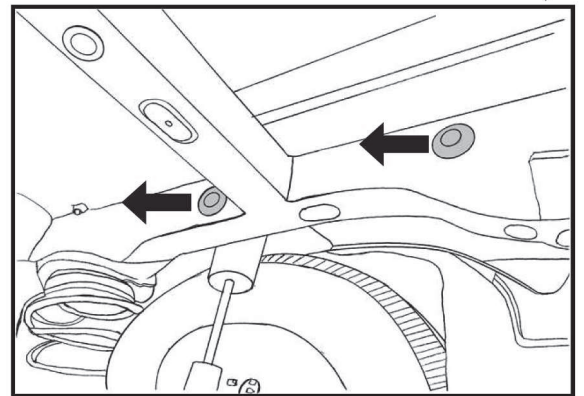
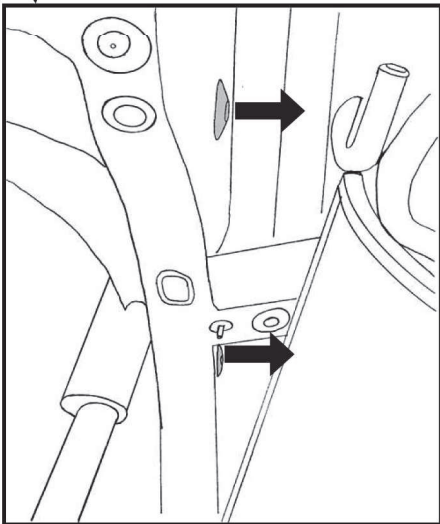
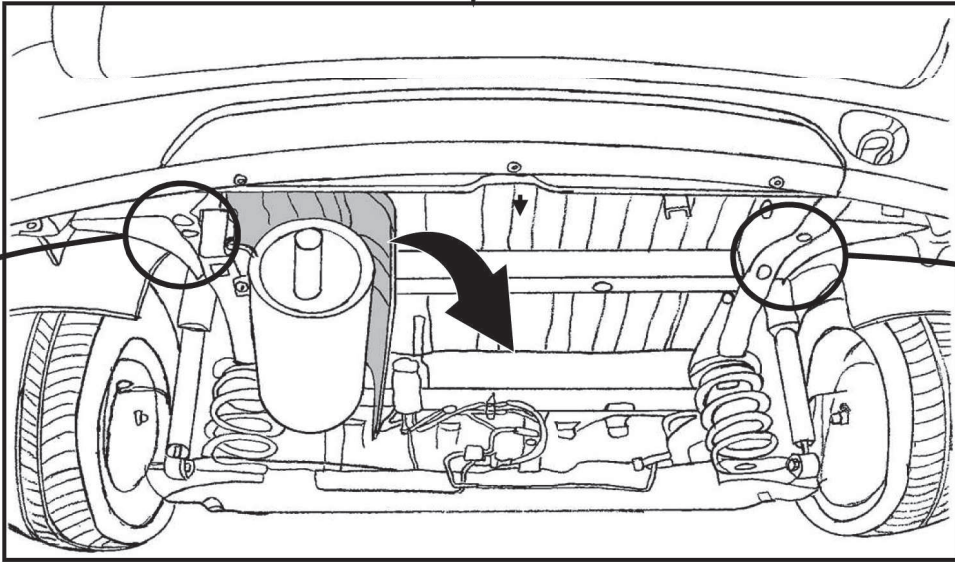
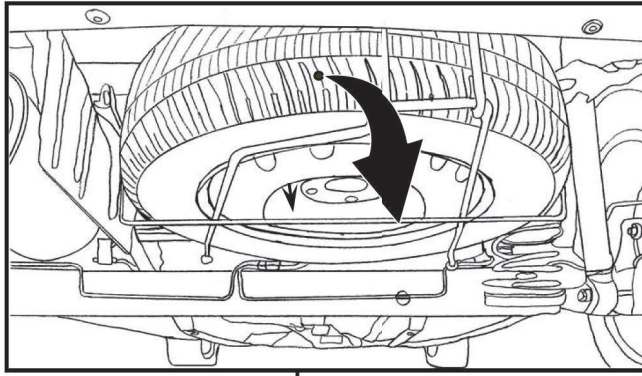



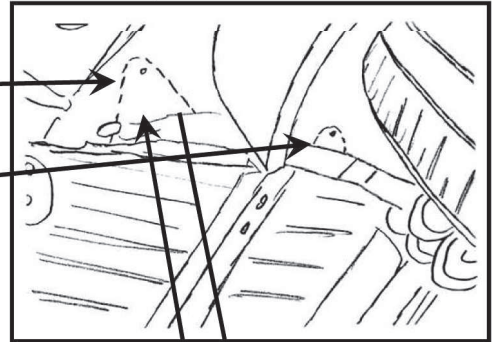
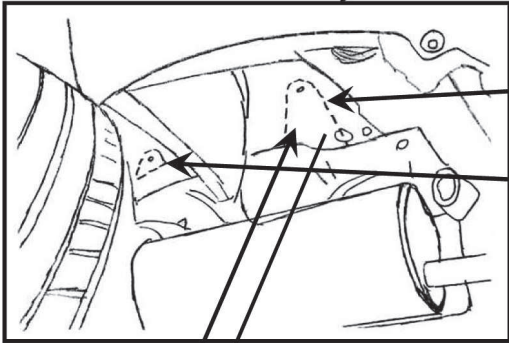
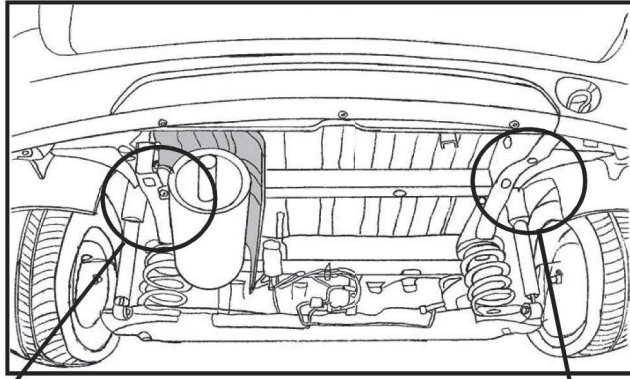

1  
4

5  
8

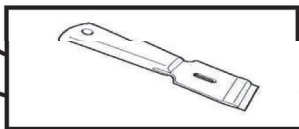
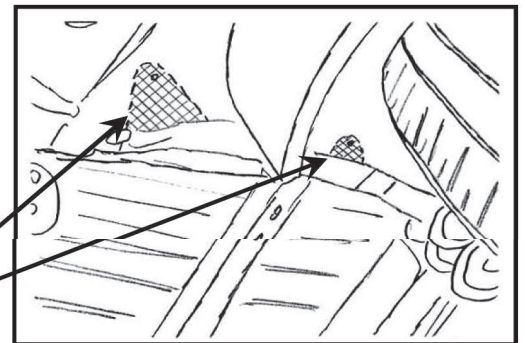
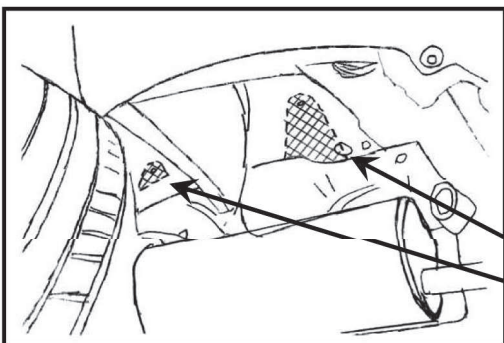
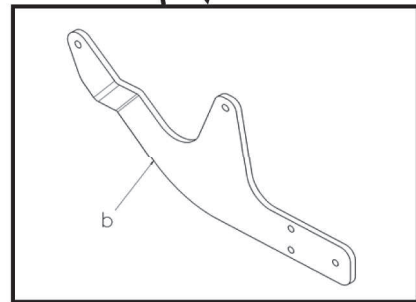
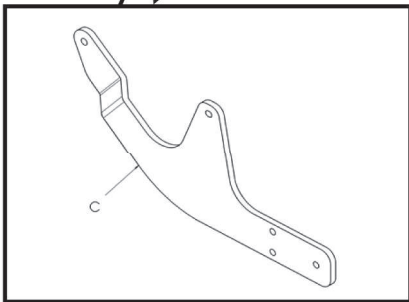

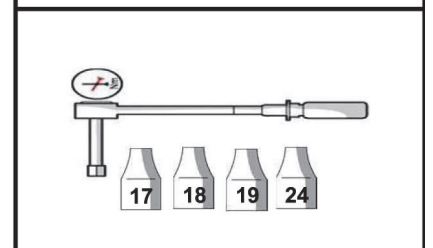
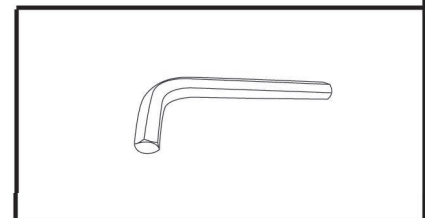
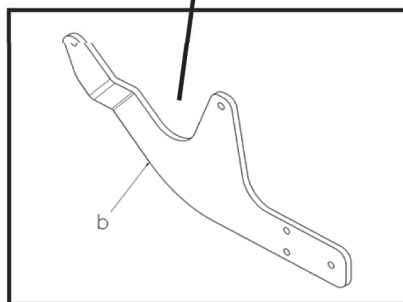
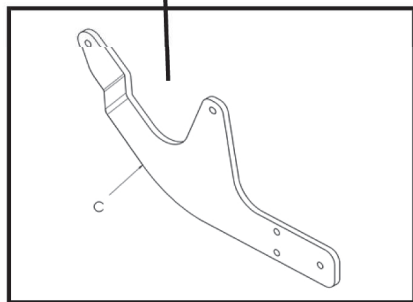
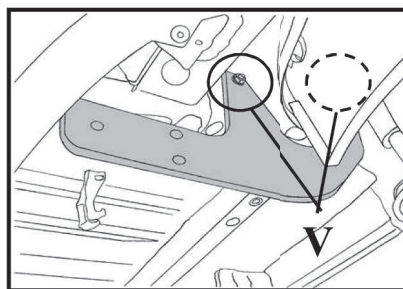
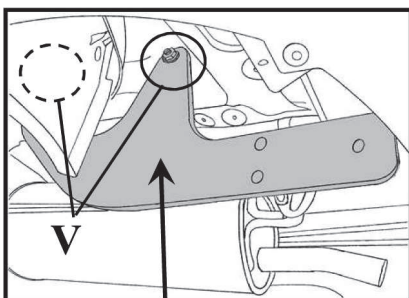
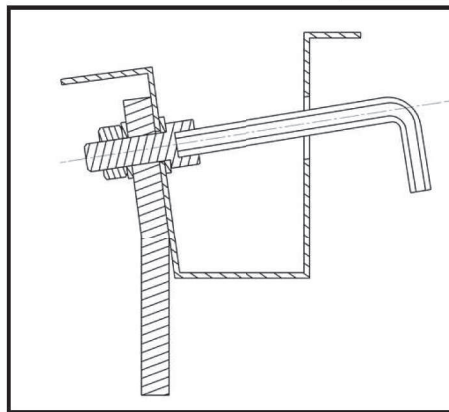
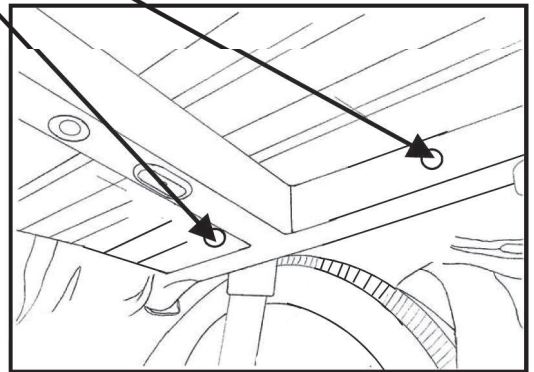
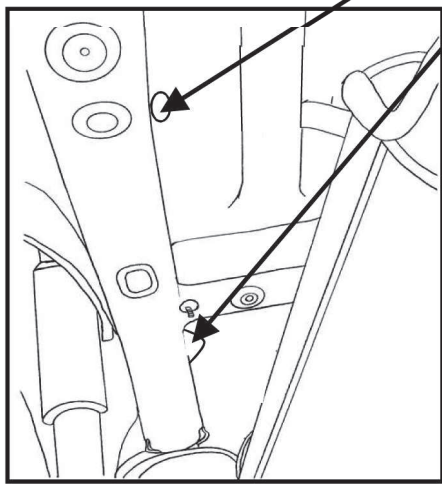
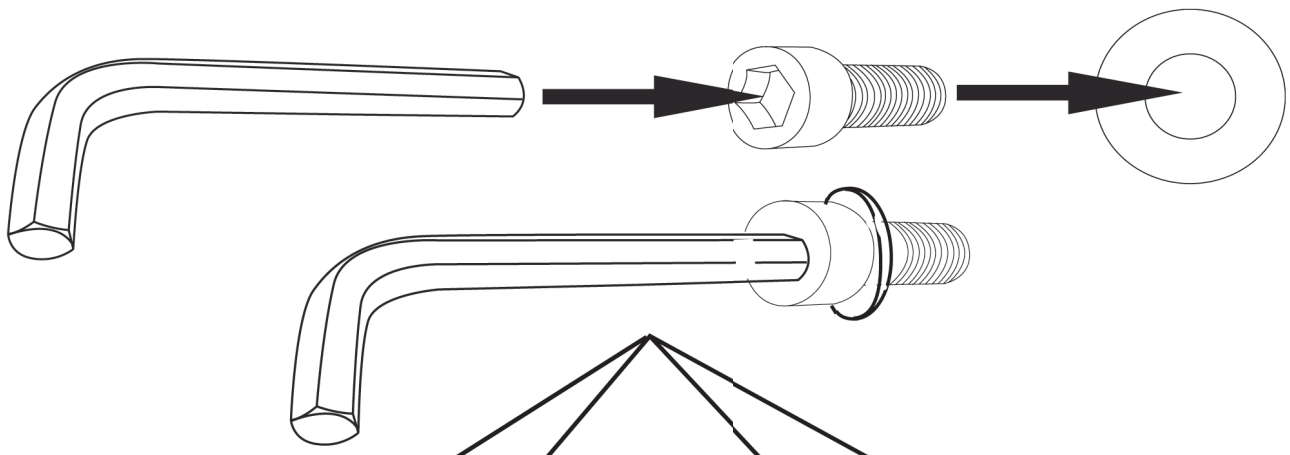

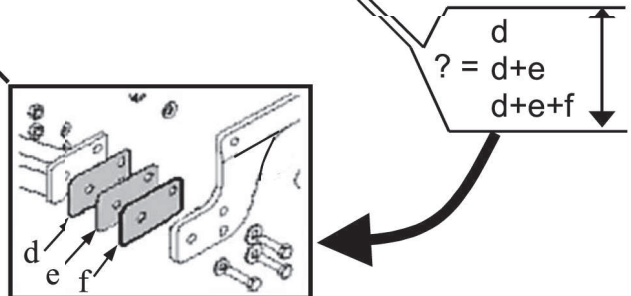
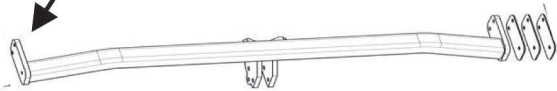
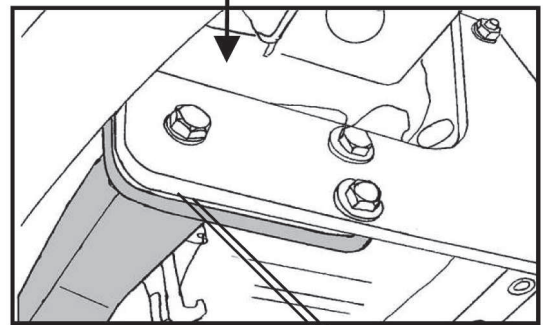
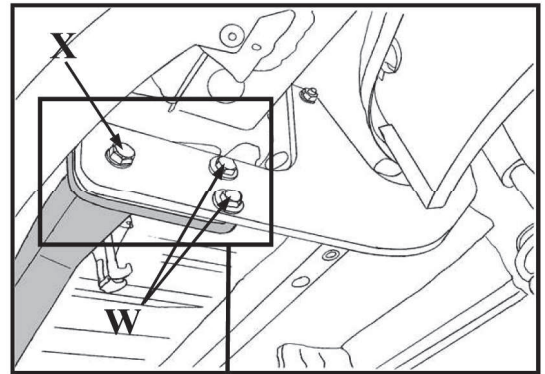
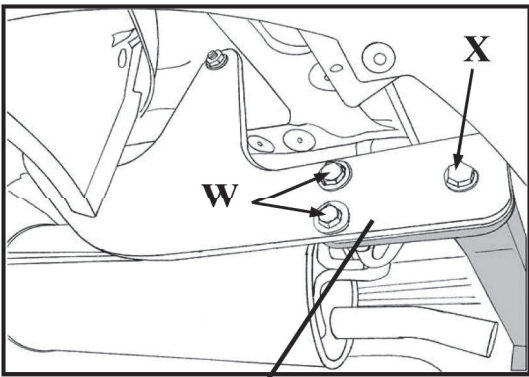
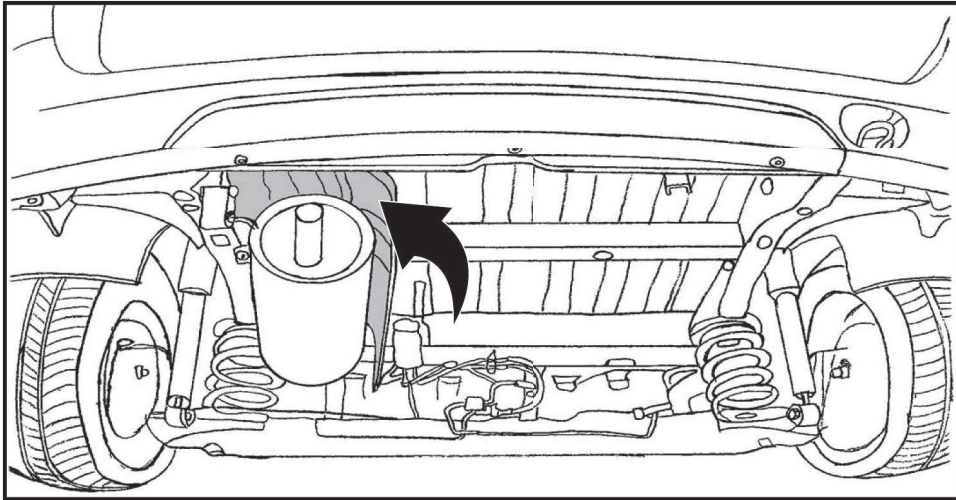
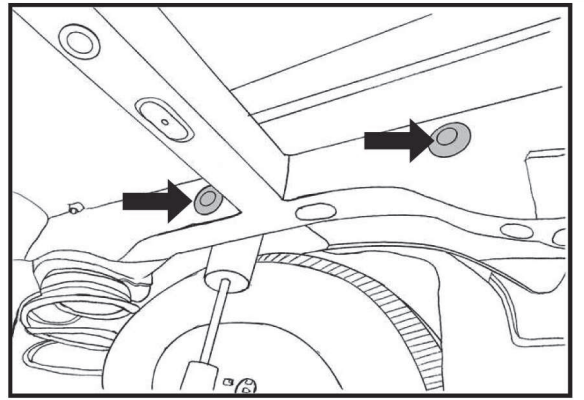
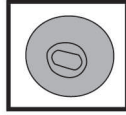
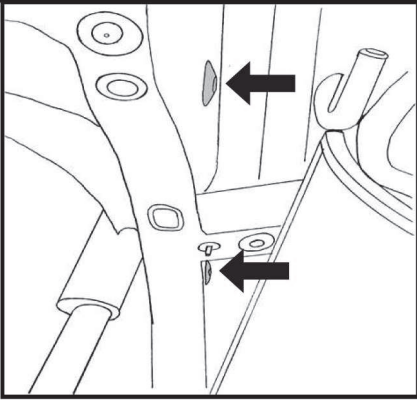

$d$   
 $? = d+e$   
 $d+e+f$

