

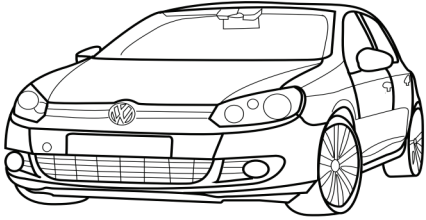

SIARR

WESTFALIA



Golf VI



1 700 kg



100 kg



11-108 : 20.9 kg
5246 : 18.4 kg



2 200 kg

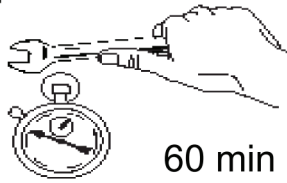

60 min



9.4 kN

e24*94/20*00*0148

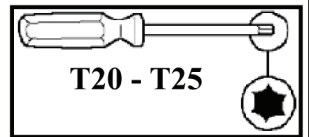
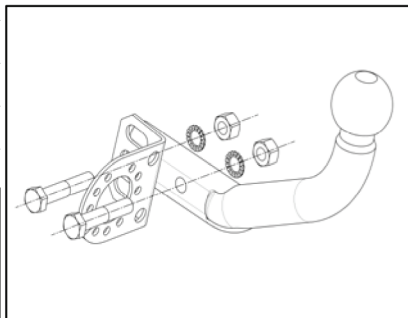
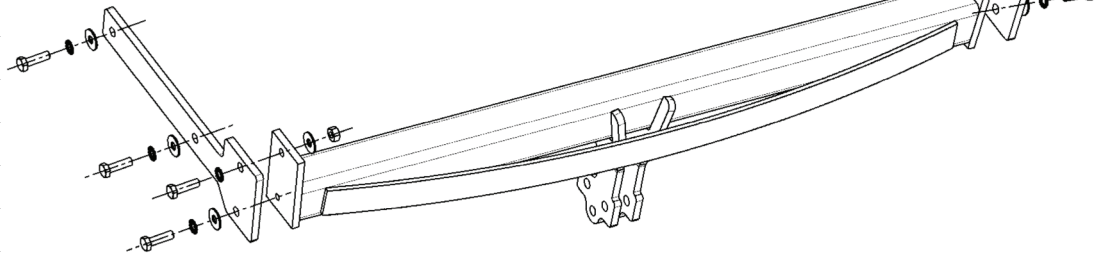
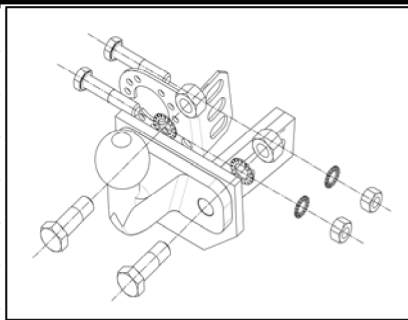

T20 - T25

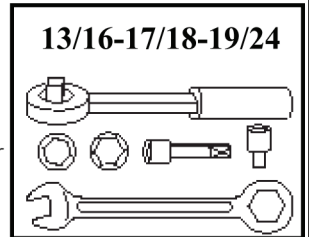



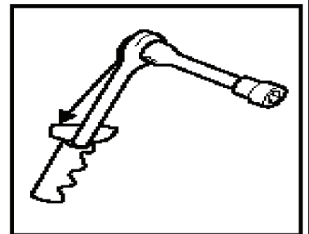



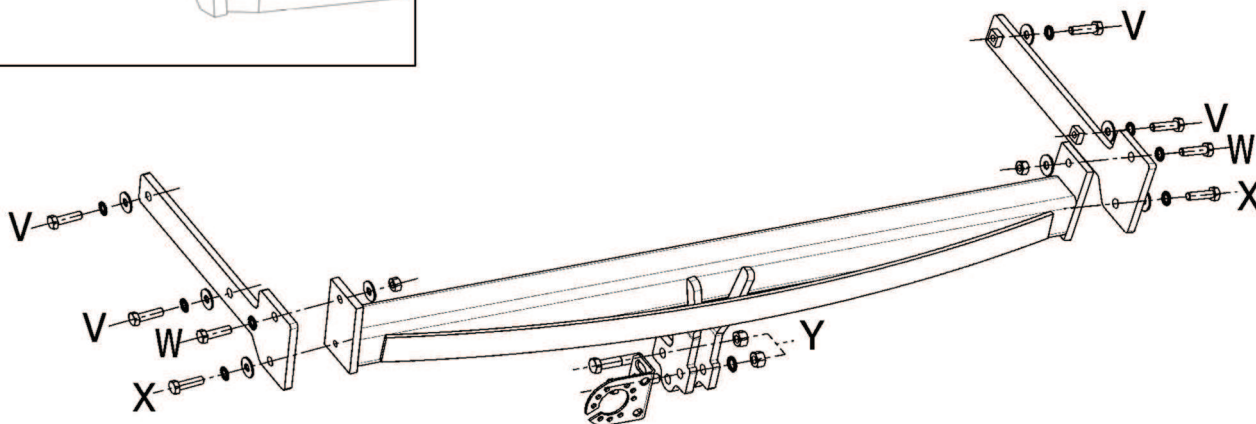
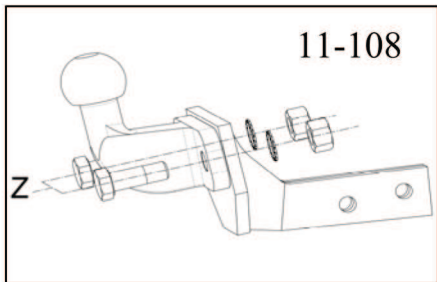









13/16-17/18-19/24



11-108



V	 HM10x35 - cl 8.8 - 40Nm	x 4
	 DEC10	x 4
	 L 10/27	x 4
W	 HM10x35 -cl 8.8 - 40Nm	x 2
	 L 10/27	x 2
	 DEC10	x 2
	 HM10 cl 8 - 40Nm	x 2
X	 HM10x35 - cl 8,8 - 40Nm	x 2
	 L 10/27	x 2
	 DEC10	x 2
Y	 HM12x60 - cl 8,8 - 65Nm	x 2
	 DEC12	x 2
	 HM12 - cl 8 - 65 Nm	x 2
Z	 HM16x45 - cl 8,8 - 170Nm	x 2
	 DEC16	x 2
	 HM16 - cl 8 - 170Nm	x 2

